

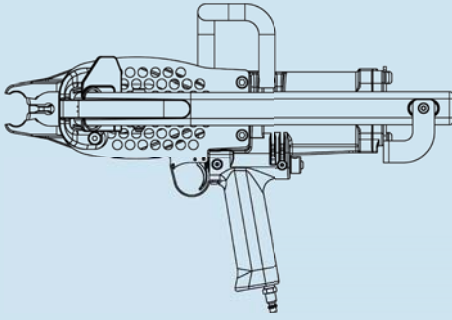

F CL45 GABION TOOL

- Double grip ensures a non-slip handling and reduces fatigue
- Simple, rugged design to withstand the harshest conditions
- Special designed forceps for good ring closure
- Saves time and labour cost

TOOL TYPE



F CL45 Gabion Tool

TOOL CHARACTERISTICS

Height	Width	Length	Weight
370 mm	240 mm	510 mm	6.3 kg
14.57 inch	9.45 inch	20.01 inch	13,89 lbs

Pressure 5 - 6 bar | 72 - 87 psi

Lubricant Aerospace Lubricants Tribolube 12

FASTENER DATA

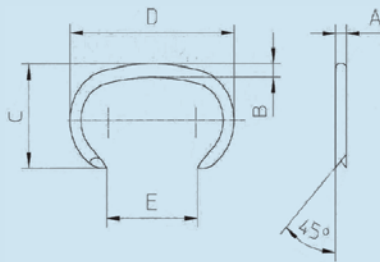

A x B: Flattening	3.05 x 2.88 mm	.120 x .112 inch
C) Height	24 mm	.945 inch
D) Outer Width	45 mm	1 3/4 inch
E) Inner Width	25-29 mm	1 - 1 1/8 inch
Magazine Capacity	100pcs	
Staple Type	BECK CL45 Gabion Ring	

VIBRATION VALUE

(UNI ISO/TS 8662-11)

is below the declaration limit set by UNI EN ISO 12100-1/2

ACTUATION & LOADING

Loading* Side Loading

*see instruction manual

APPLICATIONS

- Gabion baskets, sacks or mattresses
- Lobster traps and other traps
- Rockfall nets

FASCO S.R.L. Italy

Via B. Buozzi 2

I - 40057 Cadriano di Granarolo (BO)

Tel. +39 051 / 60 181 | Fax +39 051 / 766 325

fasco@fasco-tools.com | www.fasco-tools.com

